

Setting Global Standards



Leadership



Hong Kong Spring CIMA is part of a long and successful history.

Hong Kong Spring, an international group of Hong Kong American companies, is the largest privately owned spring making group in North America. Hong Kong Spring has more than 15 manufacturing plants and a number of speciality operations located in the United States, Canada, Mexico and Japan.

Hong Kong Spring CIMA specializes in the engineering and manufacturing of hose clamps for automotive, appliance and industrial needs. We can offer our clients unexcelled service and quality.

Asserting world class manufacturing requires an unwavering commitment to our customers needs . . . and we deliver.

Manufacturing



Our proven forming techniques in state of the art, custom designed machines, creates the highest quality along with the maximum volume requirements of our largest customers. The forming of these special alloy spring materials, combined with the in-house heat treatment and DACROTIZED process for superior corrosion

protection all add up to make the CIMA hose clamp the finest product on the market. We produce over 75 million parts per year now, and we are currently increasing future production with new equipment and technology to meet the ever growing needs of our customers. We stock the largest dual wire hose clamp inventory in North America.

*High Volume
And Cost
Effective
Production*



*Consistency
And Total
Reliability
Is Engineered
Into Every
Clamp*

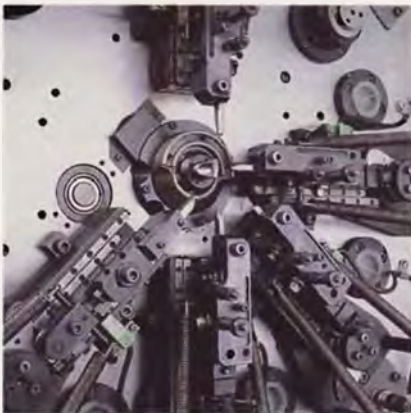

Quality Assurance



Hong Kong Spring engineers have successfully developed a unique, high tensile spring alloy material used in the production of CIMA hose clamps. In house CAD systems result in the design control of specific tooling and products used in production. Quality assurance is built into every CIMA hose clamp through extensive training of

our employees and their dedication to strict quality procedures. This is supported by our customer certified laboratory and custom designed, strain gauge. Benchmarking ourselves against our own past performance assures our continued leadership and superior performance in our industry.

Applications



CIMA Pliers have been designed by us to meet customer needs. They lower production costs by decreasing physical fatigue

while increasing assembly speed and assuring consistent clamp applications to our customers specifications.

Asserting world class manufacturing requires an unwavering commitment to our customers needs . . . and we deliver.



DIMENSIONAL CONTROL

Tests are to be made with a plug gauge, with the four dimensions: "A", "B", "C", and "D", and appropriate gauging wires as noted by "G".

Diameter B/C

After being expanded to no greater than "A" diameter of gauge, the clamp must be round within "C" gauging dimension at "B" and "C" diameter.

Diameter A/D

The clamp when opened must pass over the "A" diameter. In order to be sure that the permanent set suffered by the material after assembly is within the prescribed limits; after passing over no greater than the "A" diameter of the gauge, the clamp in the relaxed posture shall return to no greater than the "D" diameter at its narrowest point.

STANDARD

CIMA PART NO.	A	B	C	D	E	F1	F2	G	H	COLOR CODE
	CLAMP DIAMETERS			N● GO	WIRE SIZE	REFERENCE DIM.		GAGE MAX.	REF. DIM.	
	MAX.	NOM.	MIN.			MAX.	MIN.			
10068	.275	.266	.260	.250	.039	.250	.190	.004	.250	SILVER
10073	.294	.286	.274	.265	.039	.250	.190	.004	.250	GOLD
CP-5	.306	.301	.285	.280	.039	.250	.190	.004	.250	GOLD
10086	.345	.342	.339	.320	.039	.250	.190	.004	.250	SILVER
CP-6	.380	.375	.370	.350	.039	.250	.190	.004	.250	SILVER
10101	.416	.409	.401	.381	.059	.380	.250	.006	.280	GOLD
CP-7	.442	.438	.432	.405	.059	.380	.250	.006	.280	SILVER
CP-8	.510	.500	.490	.462	.059	.380	.250	.006	.280	RED
10137	.555	.539	.524	.484	.059	.380	.250	.006	.280	GOLD
CP-9	.573	.562	.551	.520	.070	.425	.250	.006	.325	SILVER
10156	.627	.614	.595	.555	.070	.425	.250	.006	.325	RED
CP-10	.640	.625	.610	.580	.070	.425	.250	.006	.325	GREEN
10164	.662	.646	.627	.586	.070	.425	.250	.006	.325	GOLD
CP-11	.703	.688	.671	.635	.078	.500	.325	.008	.360	RED
10182	.736	.716	.697	.650	.078	.500	.325	.008	.360	GOLD
CP-12	.770	.750	.730	.690	.078	.500	.325	.008	.360	SILVER
10102	.812	.795	.772	.720	.078	.500	.325	.008	.360	GOLD
CP-13	.832	.812	.792	.740	.078	.500	.325	.008	.360	GREEN
CP-14	.900	.875	.850	.800	.086	.550	.375	.008	.400	GOLD
10231	.928	.909	.882	.826	.086	.550	.375	.008	.400	RED
CP-15	.968	.938	.906	.855	.086	.550	.375	.008	.400	SILVER
CP-16	1.031	1.000	.969	.915	.098	.560	.375	.008	.450	GOLD
CP-17	1.090	1.062	1.034	.960	.098	.560	.375	.008	.450	RED
10275	1.107	1.082	1.050	.984	.098	.560	.375	.008	.450	GOLD
CP-18	1.150	1.125	1.100	1.030	.098	.560	.375	.008	.450	SILVER
CP-19	1.218	1.188	1.156	1.095	.110	.660	.450	.010	.480	GREEN
10313	1.260	1.232	1.196	1.117	.110	.660	.450	.010	.480	GOLD
CP-20	1.280	1.250	1.219	1.145	.110	.660	.450	.010	.480	RED
CP-21	1.344	1.312	1.281	1.210	.110	.660	.450	.010	.480	SILVER
CP-22	1.405	1.377	1.335	1.260	.118	.750	.500	.010	.540	GREEN
10356	1.433	1.401	1.362	1.279	.118	.750	.500	.010	.540	RED
CP-23	1.500	1.465	1.425	1.330	.118	.750	.500	.010	.540	GOLD
CP-24	1.531	1.500	1.469	1.350	.126	.750	.500	.010	.560	SILVER
CP-25	1.592	1.561	1.530	1.411	.126	.750	.500	.010	.560	SILVER
CP-26	1.692	1.625	1.578	1.475	.126	.750	.500	.010	.560	GOLD
CP-28	1.797	1.750	1.703	1.580	.126	.750	.500	.010	.560	SILVER
CP-30	1.937	1.875	1.812	1.720	.126	.750	.500	.010	.560	SILVER
CP-31	2.000	1.938	1.875	1.799	.137	.800	.550	.010	.590	SILVER
CP-32	2.061	2.000	1.939	1.830	.137	.800	.550	.010	.590	GOLD
CP-34	2.187	2.125	2.062	1.946	.137	.800	.550	.010	.590	SILVER
CP-35	2.250	2.187	2.125	1.975	.137	.800	.550	.010	.590	SILVER
CP-36	2.300	2.250	2.187	2.000	.137	.800	.550	.010	.590	SILVER

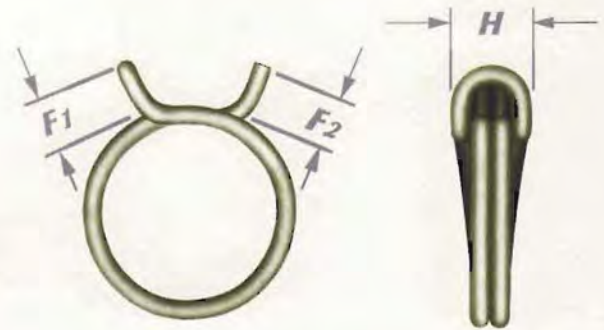
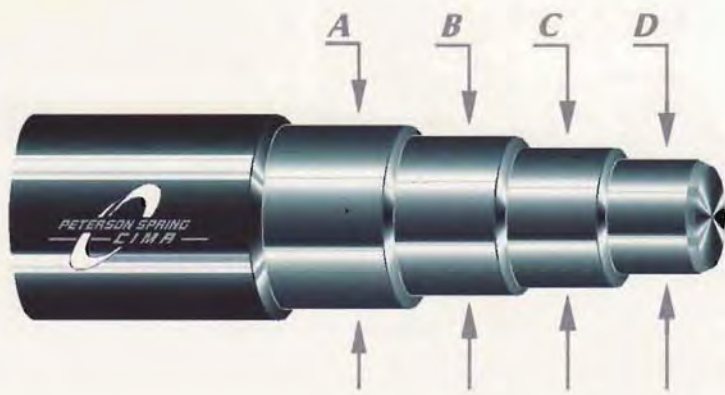

NOTE: For additional corrosion protection ask for our STAINLESS STEEL HOSE CLAMPS

METRIC

CIMA PART NO.	A	B	C	D	E	F ₁	F ₂	G	H	COLOR CODE
	CLAMP DIAMETERS			NO GO	WIRE SIZE	REFERENCE DIM.		GAGE MAX.	REF. DIM.	
	MAX.	NOM.	MIN.			MAX.	MIN.			
10068	6.99	6.76	6.60	6.35	1.00	6.35	4.80	.105	6.35	SILVER
10073	7.47	7.26	6.96	6.73	1.00	6.35	4.80	.105	6.35	GOLD
CP-5	7.80	7.60	7.30	7.10	1.00	6.35	4.80	.105	6.35	GOLD
10086	8.80	8.70	8.60	8.10	1.00	6.35	4.80	.105	6.35	SILVER
CP-6	9.65	9.50	9.40	8.90	1.00	6.35	4.80	.105	6.35	SILVER
10101	10.57	10.39	10.19	9.68	1.50	9.65	6.35	.153	7.10	GOLD
CP-7	11.25	11.13	11.00	10.28	1.50	9.65	6.35	.153	7.10	SILVER
CP-8	13.00	12.55	12.50	11.73	1.50	9.65	6.35	.153	7.10	RED
10137	14.10	13.73	13.36	12.36	1.50	9.65	6.35	.153	7.10	GOLD
CP-9	14.58	14.31	14.00	13.75	1.70	10.80	6.35	.153	8.25	SILVER
10156	15.93	15.60	15.11	14.10	1.70	10.80	6.35	.153	8.25	RED
CP-10	16.26	15.88	15.49	14.73	1.70	10.80	6.35	.153	8.25	GREEN
10164	16.81	16.41	15.93	14.88	1.70	10.80	6.35	.153	8.25	GOLD
CP-11	17.86	17.48	17.04	16.13	1.98	12.70	8.26	.203	9.14	RED
10182	18.69	18.19	17.70	16.51	1.98	12.70	8.26	.203	9.14	GOLD
CP-12	19.50	19.00	18.50	17.50	1.98	12.70	8.26	.203	9.14	SILVER
10202	20.62	20.19	19.61	18.25	1.98	12.70	8.26	.203	9.14	GOLD
CP-13	21.13	20.62	20.12	18.80	1.98	12.70	8.26	.203	9.14	GREEN
CP-14	22.75	22.13	21.50	20.25	2.19	13.97	9.53	.203	10.16	RED
10231	23.57	23.09	22.40	20.98	2.19	13.97	9.53	.203	10.16	GOLD
CP-15	24.59	23.83	23.01	21.72	2.19	13.97	9.53	.203	10.16	SILVER
CP-16	26.29	25.50	24.61	23.24	2.49	14.22	9.53	.254	11.43	GOLD
CP-17	27.68	26.97	26.26	24.38	2.49	14.22	9.53	.254	11.43	RED
10275	28.12	27.48	26.67	24.99	2.49	14.22	9.53	.254	11.43	GOLD
CP-18	29.21	28.58	27.94	26.16	2.49	14.22	9.53	.254	11.43	SILVER
CP-19	30.94	30.18	29.36	27.81	2.80	16.76	11.43	.254	12.19	GREEN
10313	32.00	31.29	30.38	28.37	2.80	16.76	11.43	.254	12.19	GOLD
CP-20	32.51	31.75	30.96	29.08	2.80	16.76	11.43	.254	12.19	RED
CP-21	34.14	33.32	32.54	30.73	2.80	16.76	11.43	.254	12.19	SILVER
CP-22	35.69	34.98	33.91	32.00	3.00	19.00	12.70	.254	13.72	GREEN
10356	36.40	35.59	34.59	32.49	3.00	19.00	12.70	.254	13.72	RED
CP-23	38.10	37.21	36.20	33.78	3.00	19.00	12.70	.254	13.72	GOLD
CP-24	38.89	38.10	37.31	34.29	3.20	19.00	12.70	.254	14.22	SILVER
CP-25	40.44	39.65	38.86	35.84	3.20	19.00	12.70	.254	14.22	SILVER
CP-26	42.98	41.28	40.08	37.47	3.20	19.00	12.70	.254	14.22	GOLD
CP-28	45.64	44.45	43.26	40.13	3.20	19.00	12.70	.254	14.22	SILVER
CP-30	49.20	47.63	46.02	43.69	3.20	19.00	12.70	.254	14.22	SILVER
CP-31	50.80	49.23	47.63	45.19	3.50	20.32	13.97	.254	14.99	SILVER
CP-32	52.35	50.80	49.25	46.48	3.50	20.32	13.97	.254	14.99	GOLD
CP-34	55.55	53.98	52.37	49.43	3.50	20.32	13.97	.254	14.99	SILVER
CP-35	57.15	55.55	53.98	50.17	3.50	20.32	13.97	.254	14.99	SILVER
CP-36	58.42	57.15	55.55	50.80	3.50	20.32	13.97	.254	14.99	SILVER



Peterson Spring CIMA
16805 Heimbach Road
Three Rivers, MI 49093
Phone: (616) 279 - 7421
Fax: (616) 279 - 7265



Peterson American Corporation
21200 Telegraph Road
Southfield, MI 48086 - 5059
Phone: (810) 799 - 5400
Fax: (810) 357 - 3176